



PRODUCT: AUTOMATED CATWALKS

DATE: May 11, 2009

SUBJECT: Longer Safety Pins for PC3000 Carrier

SERIAL NUMBERS: All

DISCUSSION: Canrig has developed a longer safety pin for the PowerCAT 3000 series. The new configuration lengthens the safety pin to 9-3/4" from 5-1/4". This is designed to reduce the risk of a tubular being ejected from the carrier in the event the skate is being used to tail back pipe. Please note that this is not the recommended procedure for laying down pipe. Refer to the operating manual for the correct procedure.

Operation Note: With the new Safety Pin Kit (AY50643) installed, the maximum casing diameter is reduced from 20" to 18-3/4".

RECOMMENDATION: If deemed a necessary upgrade, contact Canrig to purchase the PC3000 Safety Pin Retro Fit kit (P/N AY50643). The kit includes the parts and instructions to upgrade the carrier to utilize the longer safety pins.

This page intentionally left blank



Engineering Bill of Material

Part: AY50643
Description: PC3000 SAFETY PIN RETRO FIT

Eng ID: 0
Drawing ID: AY50643

Rev No: 03

Item	Qty	Units	Part ID	Eng ID	Description
01	12.00	EA	141102537		ARM, LONG, SAFETY PIN
02	6.00	EA	156100257		BLOCK, GUIDE, LONG SAFETY PIN
03	6.00	EA	156100259		PIN, SAFETY, LONG
04	6.00	EA	M10668		GREASE NIPPLE, 1/8 NPT, 90°
06	2.00	EA	HN-0375NC-GR8		HEX NUT, 3/8-16UNC GR8
07	2.00	EA	FW-0375-A		WASHER, F, 3/8, PLAIN, TYPE A
08	2.00	EA	LW-0375-HS		LOCKWASHER, 3/8 HELICAL SPRING
09	2.00	EA	HH-0375NC-0250-GR8		CAPSCR, HEX HD, 3/8-16UNC x 2.50, GR8
10	1.00	EA	156100260		JIG, DRILL, SAFETY PIN

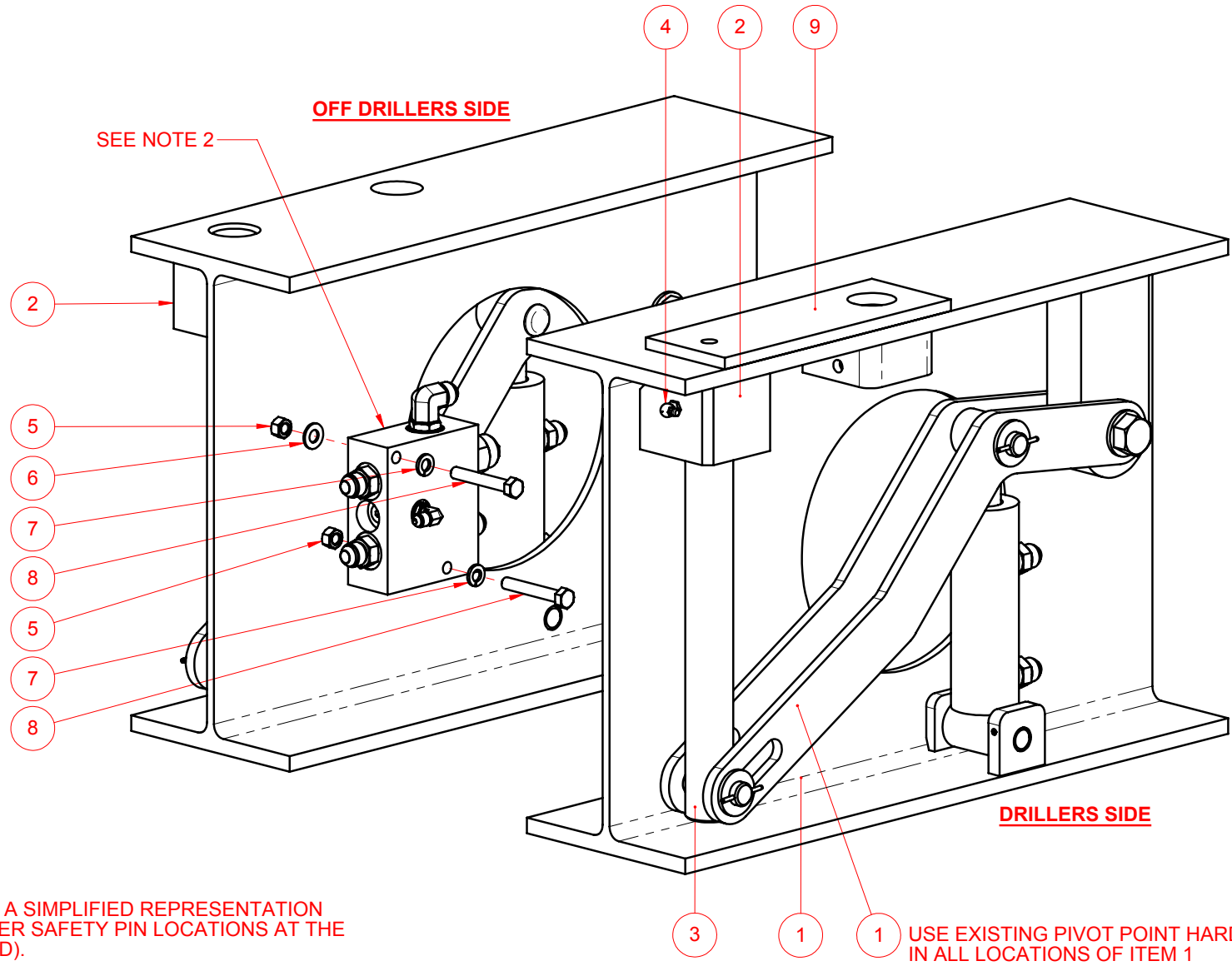

NOTE:

- 1) THIS ILLUSTRATION IS A SIMPLIFIED REPRESENTATION OF THE PC3000 CARRIER SAFETY PIN LOCATIONS AT THE FRONT END (RAMP END).
- 2) THE REVISED MANIFOLD MOUNTING OCCURS IN ONLY ONE INSTANCE (CLOSEST TO THE FRONT END).

USE EXISTING PIVOT POINT HARDWARE IN ALL LOCATIONS OF ITEM 1

REV.	DESCRIPTION	DATE
03		20-May-2009
02	ITEM 1 AND ITEM 2 GEOMETRY CHANGED, ADDED PAINT NOTE.	06-May-2009
01	RFM	16-Mar-2009

ALL RIGHTS RESERVED

THE DRAWINGS, INFORMATION AND SUBJECT MATTER HEREOF ARE THE CONFIDENTIAL, SOLE AND EXCLUSIVE PROPERTY OF CANRIG DRILLING TECHNOLOGY CANADA LTD, AND ARE NOT TO BE COPIED, REPRODUCED, OR USED IN ANY MANNER FOR OR DIRECTION.

CANRIG
DRILLING TECHNOLOGY LTD.

7475 51 Street SE
Calgary, Alberta, Canada, T2C 4L6
Website: www.canrig.com
Bus. (403) 237-6400 Fax. (403) 233-2667

TITLE:
PC3000 SAFETY PIN RETRO-FIT

DRAWN BY: TLK	DATE: 11-Mar-2009	DRAWING NO: AY50643	SHEET: 1 OF 3	REV: 03
------------------	----------------------	------------------------	------------------	------------

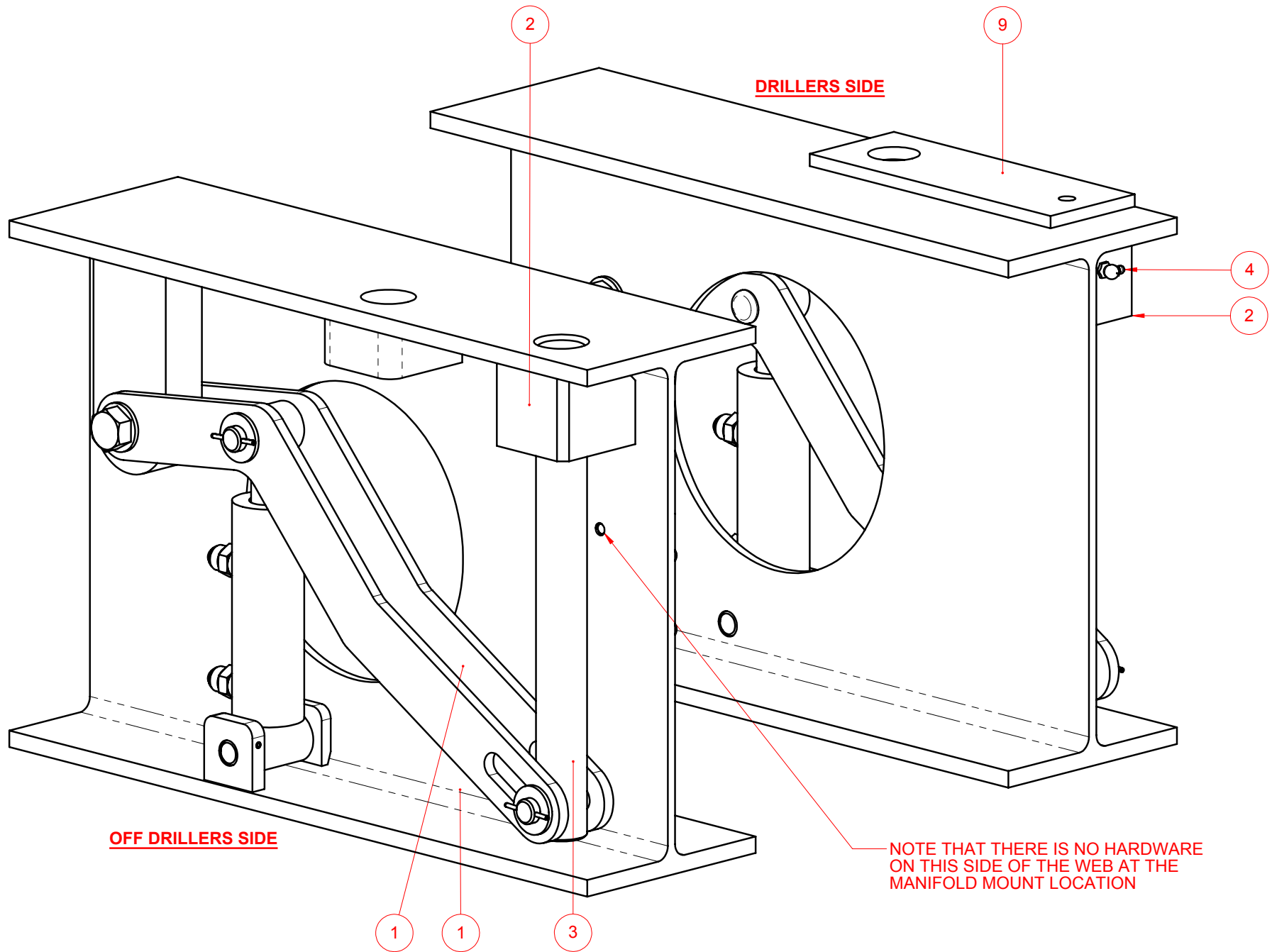

<p>ALL RIGHTS RESERVED</p> <p>THE DRAWINGS, INFORMATION AND SUBJECT MATTER HEREOF ARE THE CONFIDENTIAL, SOLE AND EXCLUSIVE PROPERTY OF CANRIG DRILLING TECHNOLOGY CANADA LTD, AND ARE NOT TO BE COPIED, REPRODUCED, OR USED IN ANY MANNER FOR</p> <p>OR DIRECTION.</p>		<p>7475 51 Street SE Calgary, Alberta, Canada, T2C 4L6 Website: www.canrig.com Bus. (403) 237-6400 Fax. (403) 233-2667</p>		<p>TITLE:</p> <p style="text-align: center;">PC3000 SAFETY PIN RETRO-FIT</p>	
		<p>DRAWN BY:</p> <p style="text-align: center;">TLK</p>	<p>DATE:</p> <p style="text-align: center;">11-Mar-2009</p>	<p>DRAWING NO:</p> <p style="text-align: center;">AY50643</p>	<p>SHEET:</p> <p style="text-align: center;">2 OF 3</p>
				<p>REV:</p> <p style="text-align: center;">03</p>	

INFORMATION:

For a complete list of all bulletins go to www.canrig.com

For further information contact:

Field Service
Canrig Drilling Technology Ltd.

14703 FM 1488
Magnolia, Texas 77354
Phone: 281.259.8887
Fax: 281.259.8158

7475 51 Street SE
Calgary, AB T2C 4L6
Phone: 403.237.6400
Fax: 403.536.4605

This page intentionally left blank