

Change Bulletin

No: CB026

Rev: 0

Date: 19 Feb 2008

Description: Revision of 7" ICDS Mandrel Load Capacity to 400 Ton



Tesco Corporation
6204 – 6A Street SE
Calgary, AB. T2H 2B7
Phone: (403) 692 5700
www.tescocorp.com

BACKGROUND INFORMATION:

This bulletin allows the mandrel described below to be re-rated to 400 Ton from the previous rating of 290 Ton. Finite element analytical work was carried out (EM000163) in conjunction with C-FER tensile pull test results (TX05025). The test results were used to calibrate the finite element modeling in order to derive an accurate stress level, profile and identify the most critical regions. The ECN-152-0002 was created to update the required mandrel drawing. All future new mandrel builds will be stamped 400 Ton.

AFFECTED PRODUCT:

This change affects only the 5 ramp, 7" casing mandrels with part numbers: 17863-1 and 17863-2 and excludes all 4 ramp, 7" casing mandrels. This change is not a mandatory re-certification of existing mandrels but is provided for those end users wishing to have their mandrels re-rated for commercial reasons.

General Assembly or Model or Process

Description	Part No.	Serial No.
MANDREL,7"CASING 5-RAMP, ICDS	17863-1	All
MANDREL,7"CASING 5-RAMP, ICDS	17863-2	All

ACTION REQUIRED:

Should a business unit elect to re-certify a specific mandrel to 400 Ton the following process must be followed:

- i. Identify the part number and serial number of the mandrel to be re-certified.
- ii. Forward the latest MPI report for the mandrel to Tesco QC department. If the MPI report is greater than 30 operating days old then a new MPI inspection is required according to MPI specification ASTM E709. The MPI report will be supplied to Tesco QC department and will include the appropriate serial number of the component being examined.
- iii. Tesco QC will review the reports and forward to Tesco Engineering for final review.
- iv. Once Tesco Engineering and QC have determined that there are no defects in the mandrel a signed Certificate of Compliance will be issued. The certificate will state that the mandrel is re-certified for a maximum load of 400 Ton.
- v. Tesco QC will update their database with the re-certification details.
- vi. Once the business unit receives the Certificate of Compliance the mandrel must be re-identified as follows:

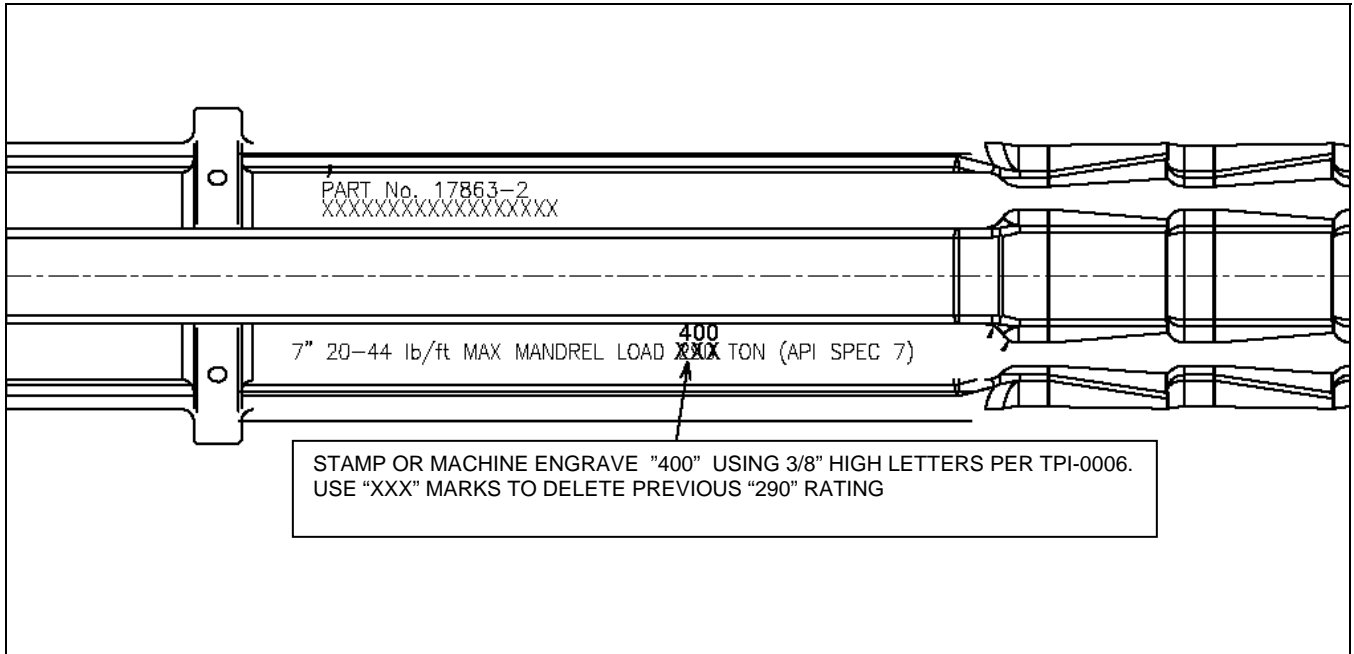

Contact your local TESCO Parts and Service Center for further information regarding this bulletin and or supply of affected components noted above.