



Model: See Affected Models	Jun. 10, 2020
Serial #: All	
Product Bulletin # PC-047 v 1.0	

## Adjusting Cable Tension Roller Bar

---

This bulletin describes the steps to adjust the cable tension roller bar. Exercise necessary precautions when working on tasks that require components to be under tension or equipment to be powered.

### Affected Models

- Canrig Automated Power Catwalk models PC3000, PC4000 and PC4100.

### Procedure



**Warning!**

Use caution with rotating parts, pinch points, and springs under tension while performing this procedure.



**Note**

Prior to starting the procedure, ensure that the winch cables are properly spooled and that each wrap sits properly in its respective groove.

Model: See Affected Models Serial #: All	Jun. 10, 2020
---	---------------

1. Perform energy isolation on the catwalk. Follow local procedures for LOTO (Lockout/Tagout).



Figure 1: Winch Cable Tensioning Roller Bar

2. When looking at the winch spring adjustment nuts and bracket, ensure the bracket is configured in the proper orientation with the bracket attachment bolts on the same side as the spring. Then ensure that one tensioning nut is on the spring side, and the other nut on the opposite side of the bracket. See Figure 2 and Figure 3 on page 3.



**Note**

Bolt nuts should not be both on the same side of the bracket. If configured incorrectly, release the spring tension by removing the nuts and reconfigure per Figure 3 on page 3.

Model: See Affected Models	Jun. 10, 2020
Serial #: All	

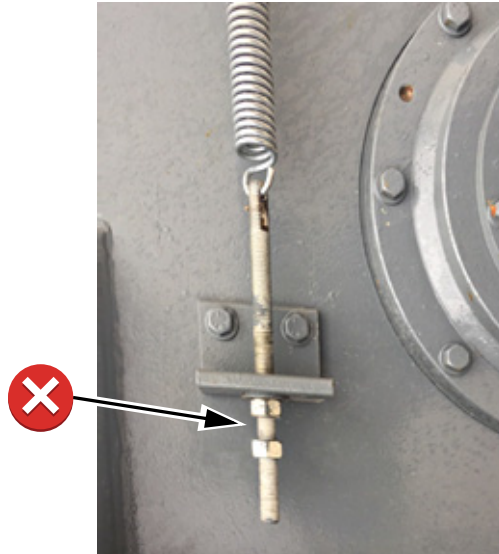

Figure 2: Incorrect Tensioning Spring Bracket and Fastener Orientation

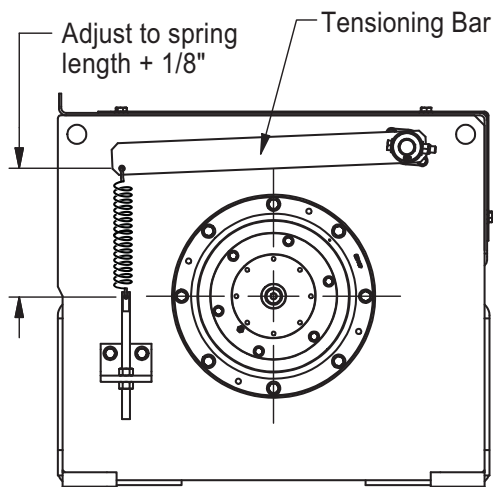

Figure 3: Correct Tensioning Spring Bracket and Fastener Orientation



**Warning!** Do not grab the tensioning bar (see Figure 3) and attempt to adjust by hand, unless all spring tension is relieved and the spring is removed.

- To tension the spring release spring side lock nut on adjustment screw.

Model: See Affected Models Serial #: All	Jun. 10, 2020
---	---------------

- Attach vise grips to square shank on end of adjustment screw to allow **bottom nut** to turn without spinning on spring. Adjust the nut on the other side of the bracket as needed to get proper tension.

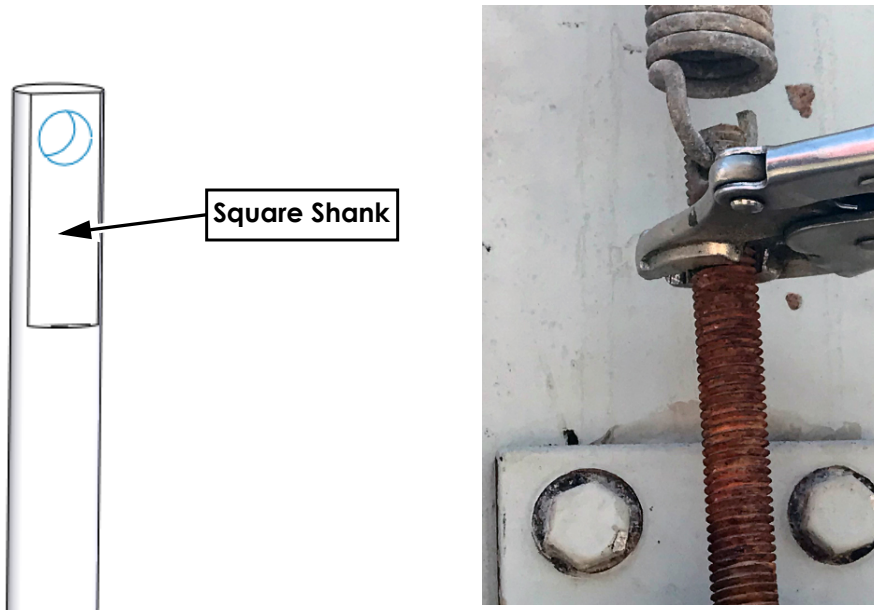

Figure 4: Vise Grips on Adjustment Screw Square Shank

- As a starting point, adjust the spring tension according to the following formula:

$$\text{Tensioning} = S_{\text{Length}} + 1/8''$$

$S_{\text{Length}}$  is the normal length of the spring

Model: See Affected Models	Jun. 10, 2020
Serial #: All	

6. With a feeler gauge check for clearance between winch cables and roller looking for approximate 0.015" clearance, the distance between the cables and the roller length might not be equal, see step 7 for other adjustment. The goal of the adjustment is to ensure the roller prevents the cables from jumping out of the groove without having too much pressure which will damage the cables and roller. See Figure 5.

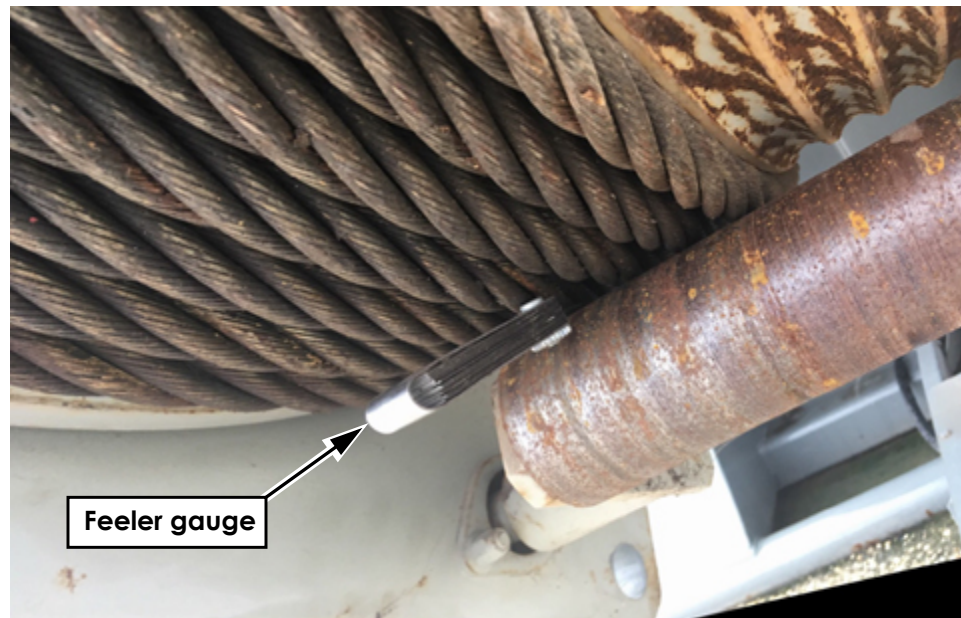

Figure 5: Feeler Gauge Gap Check – Roller to Cable

7. By design, the rod will pull down harder on the off-driller side. If the roller is tilted, you can adjust the bearing on either side and level the rod across the drum. This is done by loosening the two retaining bolts with the 3/8" nuts with a 9/16" wrench. Level out the bearings and then re-tighten the nuts to secure the position of the spring with respect to the bracket. Apply high strength threadlocker compound to secure the nuts in position when completed.
8. If still required, follow the steps below:
  - a. If 0.015" feeler will not fit between cable and roller, adjust the roller spring tension by loosening the bottom nut.
  - b. If gap is visible and exceeds 0.015" across roller, increase the spring tension by tightening bottom nut.
9. Remove energy isolation on the catwalk. Follow local procedures to safely remove LOTO.

Contact RIGLINE 24/7™ for additional information.