



Model: TM80/TM100/TM120	Nov. 13, 2024
Serial #: N/A	
Product Bulletin # TM-035 Rev 1	

Wrench Rotate Motor Case Drain Installation

On some Canrig Torq-Matic™ wrenches using a Parker hydraulic motor to rotate the wrench there have been some failures of the Parker hydraulic motor due to excess pressure on the inside of the motor. The motor has failed due to leaking of the seals. The following is a list of parts to retro-fit an existing wrench to add a case drain line from the hydraulic motor to the return line of the wrench assembly.

NOTICE

Installing the case drain line is not a required upgrade. It is an optional change that may be implemented for improved reliability.

Affected Units

This affects all Wrench models TM80, TM100, and TM120. Please see Table 1 below for affected serial numbers.

Table 1: TM Wrench Serial Numbers Affected

Model	Serial Numbers
TM80	TM800001 – TM800300
TM100	TM100001 – TM100081
TM120	TM120108 – TM120217

Recommended Actions

If you decide to install the rotate motor case drain line on Wrench models TM80/100/120, order the kit (Canrig P/N: AY25974).



Model: TM80/TM100/TM120

Serial #: N/A

Nov. 13, 2024

Table 2: Rotate Motor Drain Line Kit (AY25974)

Item	Qty	Description	P/N
1	1	TEE, FEM SWV RUN 1, MALE 1 JIC	H15-070432-16-16
2	1	REDUCER, JIC 1 FEM, 3/8 MALE	H15-070123A-16-06
3	1	FITTING, JIC 3/8 SWIVEL UNION	H15-0606-06
4	1	VLV, CHECK, IN LINE, 3/8" JIC, MJIC	H15064
5	1	ADPT, MALE 3/8 JIC, MALE 1/4 ORB	H15-070120-06-04
6	1	HOSE ASSY, 3/8, SWV STR, 9	F387TC0639060606-67.5-X-65

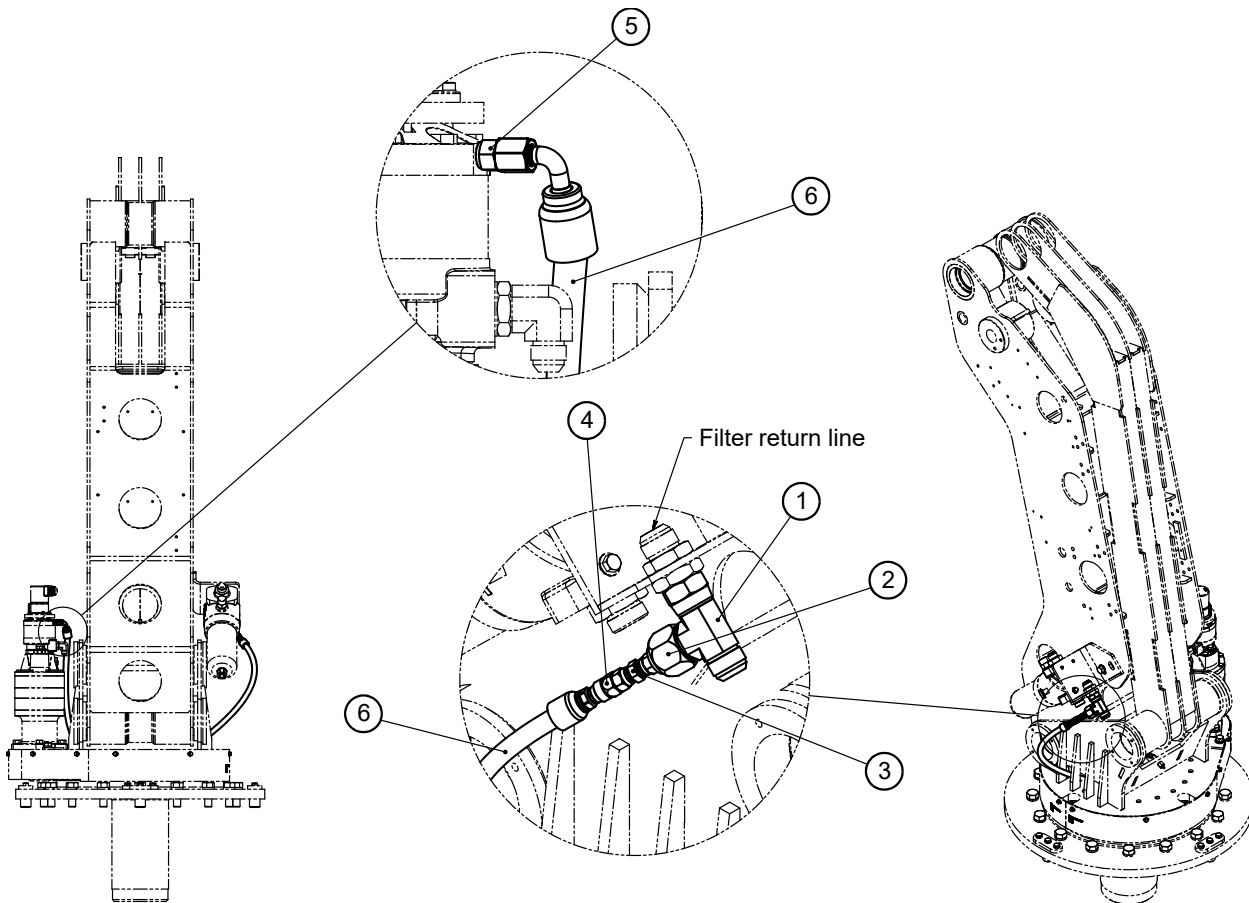

Figure 1: Rotate Motor Drain Line Kit



Model: TM80/TM100/TM120

Serial #: N/A

Nov. 13, 2024

Modification Instructions

NOTICE

See drawing # AY25974 for further details.

WARNING

Ensure there is no pressure on the hydraulic lines connected to the wrench.

1. Lock out/tag out (LOTO) the wrench and disconnect from HPU unit.
2. Remove rotate motor case drain plug as shown in Figure 2.

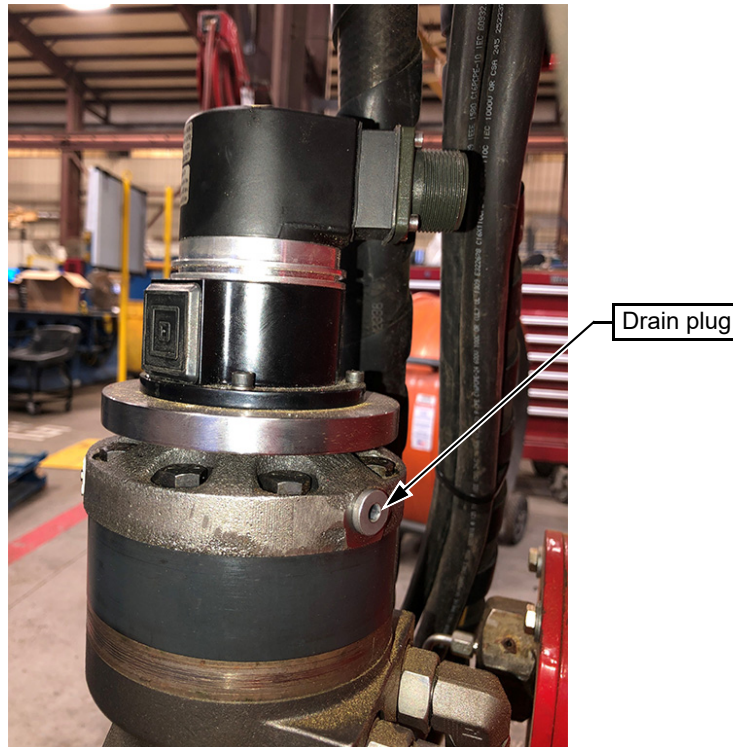

Figure 2: Rotate motor case drain plug

3. Remove HPU return line from hydraulic filter mounting bracket as shown in Figure 3.

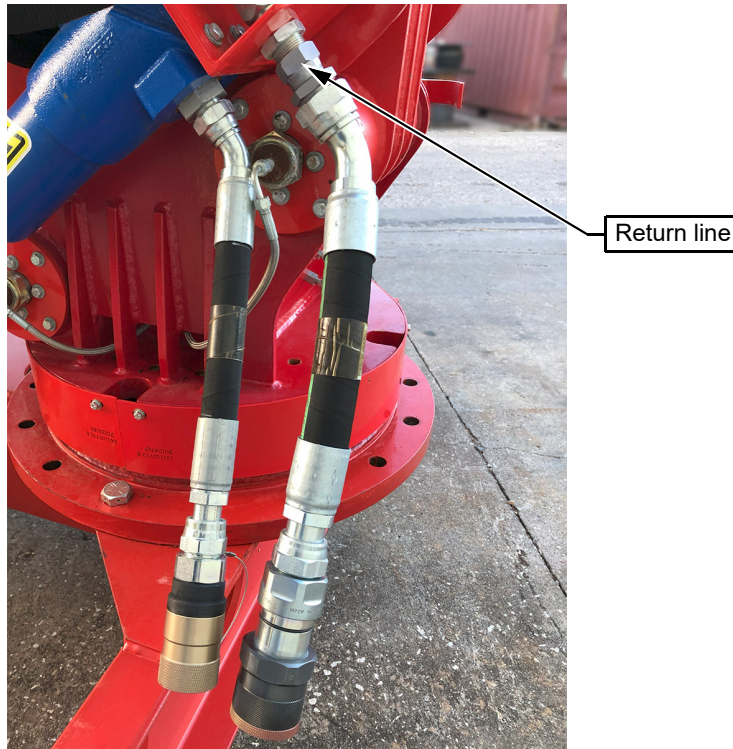

Figure 3: HPU return line removed

4. Install adapter item 5 to hydraulic rotate motor as shown in Figure 4.



Figure 4: Adapter (item 5)

5. Install fittings items 1, 2, 3 and 4 to wrench hydraulic return line as shown in Figure 5. Ensure the flow arrow on item 4 is pointing away from the filter towards the HPU return.

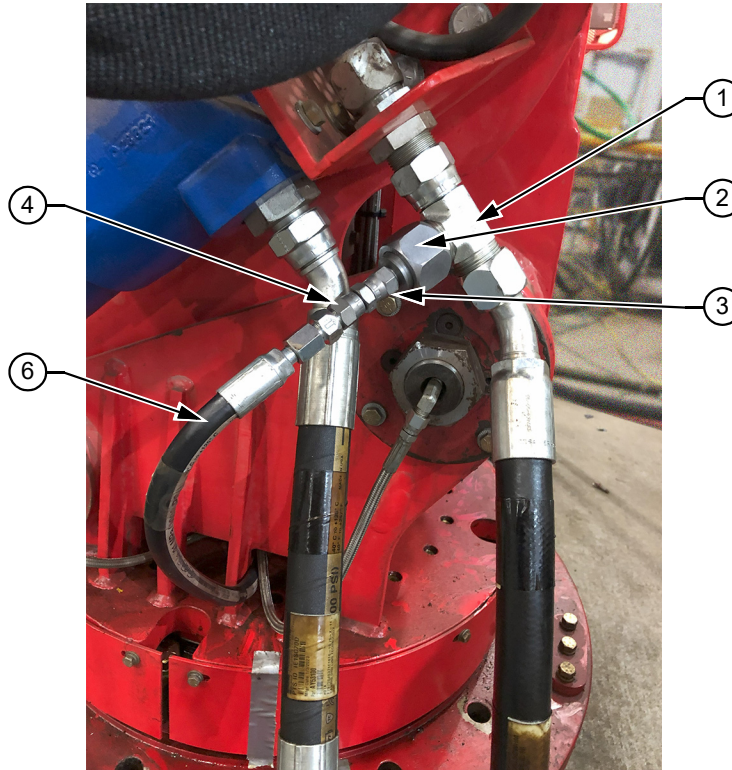

Figure 5: Wrench hydraulic return line with fittings

6. Attach hose assembly, item 6, to the case drain port installed in step 4 and to wrench return line fittings installed in step 5. Route hose through the pivot assembly as shown in Figure 4 on page 5 and Figure 5.
7. Reconnect HPU return hose and remove LOTO.